

Power Bogies for Diesel and Electric Locomotives

In this worked example we will show how the builder can produce a power bogie for the model.

The wheels sizes and basic loco data can be found in Diesel Data and Electric Data.

By building a "generic" power bogie system the builder can work from **KNOWN** starting points and **KNOWN** power capacities and **KNOWN** cornering abilities.

The principle of this system is to provide **the maximum number of possible locos for the builder** -rather than saying "no -its not possible".

Going from first principles the wheel size used on BR locos is either 3'7" or 3'9" -so what we are going to suggest is that looking for the locos on the above lists that we opt of a wheel size that is **3'8"**. This is actually within the BREL spec that says there should be no wheel with a difference in size greater than 1 inch on a power bogie. We have opted for a axle shaft size of 6mm -as this will give us the largest range of gear sizes, axles that are ¼ inch are easily catered for. We also opt for a nose suspended motor with a simple spur gear setup and that we power **each** axle.

This will sit between plates with the wheels outside of them -the external frame plates would be decorative and left to the individual builder to fabricate from brass or even plasticard. The axles will sit within ball races and there will be no springing -but there will be compensation on the C0-C0 and 1C0-C01 Bogies.

The Bogie design will use 3mm thick steel for the plates -this is thick enough to take the weight and (helpfully) it is thick enough to tap for M2 to M3. There would be horizontal steel cross members which could be bolted together and then if required silver soldered or soft soldered into a fixed strong assembly.

The C0-C0 bogie will have to have sufficient side float on the leading and trailing axles to take a 2m radius curve. We also "cheat" and if the loco requires guide axles, (such as the 1-C0-C0-1 locos), we mount a sprung "Helmholtz bogie" style assembly to the front of the C0-C0 bogie. This will not also improve the cornering ability but increase the stability of the loco at scale speeds.

Given the Back to Back spacing (58mm) and the axle float required for a C0-C0 bogie (2mm) it would make sense to go for a 56mm wide bogie this gives two 3mm thick plates and a 50mm space to cram everything between. The next thing is to work out how fast our bogie has to travel. We will use a scale 50mph for a 50mm dia wheel -which equates nicely to 1 metre per second or 381RPM. If we are using a 6mm axle then the biggest gear we can fit to the axle is a MOD 0.7 of 45 teeth (33mm dia). The motor is going to be a problem as most of the motors at this length (50mm) are fitted with 2 and 2.3mm shafts. This is going to mean a tube adaptor, (ye olde bit of brass tube), to take the 3mm bore drive gear from the motor. The motor gear will have to be cut to length as they are all supplied at 15mm long -this would have to be tapped to take an M3 grub hex screw. The axle gear we would drill at 3mm and **pin** -to ensure no slip.

The motor we have opted for is the MFA RE380 -it is a little "polite" at only 32 Grammes per Centimetre of torque but since each axle is powered it should not be that much of a problem, the stall torque is however a beefy 147 g/cm. The gearing is a little high at 12:45, but since the motor will only draw 0.5A six of them in a C0-C0 loco would only draw 3A -keeping it within the margin of most of the common R/C and PWN controllers available. The motor takes 6 Volts to 15 Volts so it is suitable for 12V "Gel Cells" and 14.4V "Race Packs".

The motor would be mounted via its two M2.5 tapped holes at the front to a face plate with 4 aero vents cut into the front. These would then have two 10mm lengths of 6mm bore tube fixed through them and an axle would move through the lengths of the tube. We would suggest that there be a small oil hole at the top. The motors would be arranged so their fan exhaust ports vented vertically (up/down).

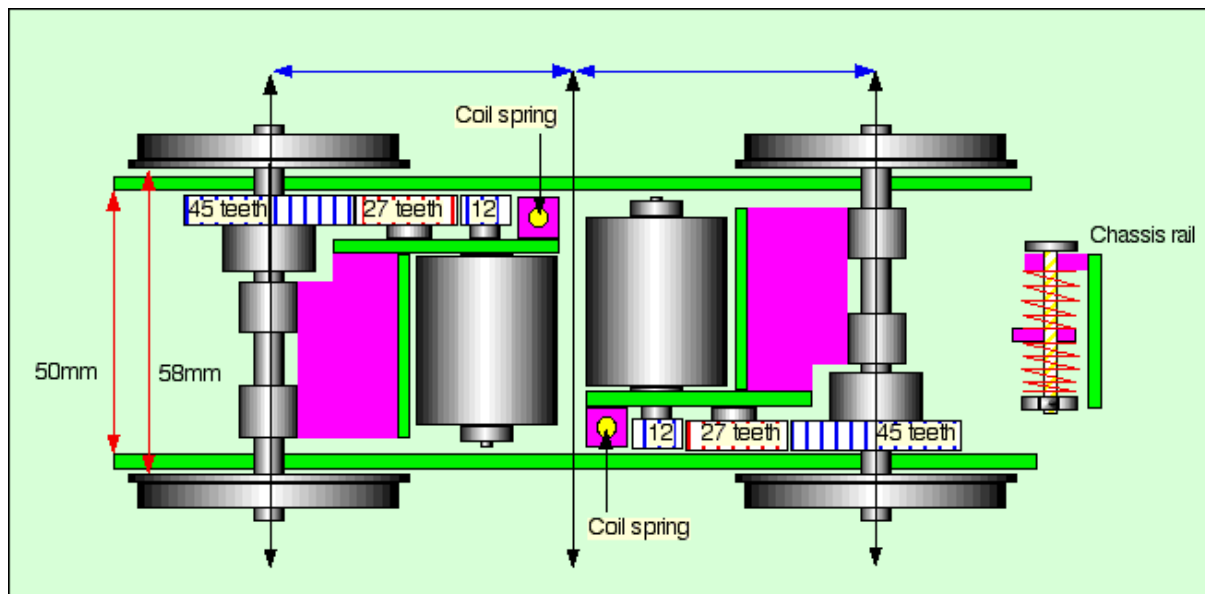

The main axle gear is 33mm by 15mm, (the boss around the gear is 15mm). On the face plate there is an idler gear of 6mm bore with 27 teeth, (this is used to clear the side of the motor), this is mounted on a stub fitted into the face plate. Both the idler gear and the motor gear are "trimmed to length" from 15mm to 8mm. The face plate is held in radial geometry with the gear axle by two 6mm bore sleeves to a transverse plate from which the face plate is held. Note that the stub axle base is re-enforced by the transverse plate.

The whole assembly is held in tension by two compression springs -which float the radial face plate between them. Undoing the screw tensioner releases the face plate and enables gear changes -(or grass stem removal)... The unit is symmetrical thus one side frame design would do both. The only things that would have to be cut into the chassis frames are the holes for the ball races and the slot for the spring assembly "tab".

The motors are mounted centrally thus ensure good dynamics when cornering and ease of wiring.

A brief calculation of the power output.

Torque at shaft = 32gcm
Reduction = 1:3.75
Torque at axle = (32 x 3.75)
= 120gcm
Torque at rail = (10 / 25) x 120
= 48gcm

B0-B0 torque = (4 x 48)
= **192gcm**

C0-C0 torque = (6 x 48)
= **288gcm**

Stall torque of motor is 147gcm therefore the initial starting impulse is:

B0-B0 = 882gcm
C0-C0 = 1,323gcm

To remove the possibility of wheel slip, the loco, (using a 3.5:1 frictional co-efficient), must exert a minimum weight on each axle of **771 grammes**.

Thus the minimum weight of a B0-B0 loco must be 3,087 grammes and that of a C0-C0 4,360 grammes.

This shows one of the plate side frames for the bogie. The holes are cut out at 10mm dia to take the ballraces and the slot cut out of the top takes a transverse 3mm x 30mm x 50mm mounting strip. The nose end springing for the motors also fits through this strip. No end re-enforcement is shown -this could be done by the use of bits of brass strip.

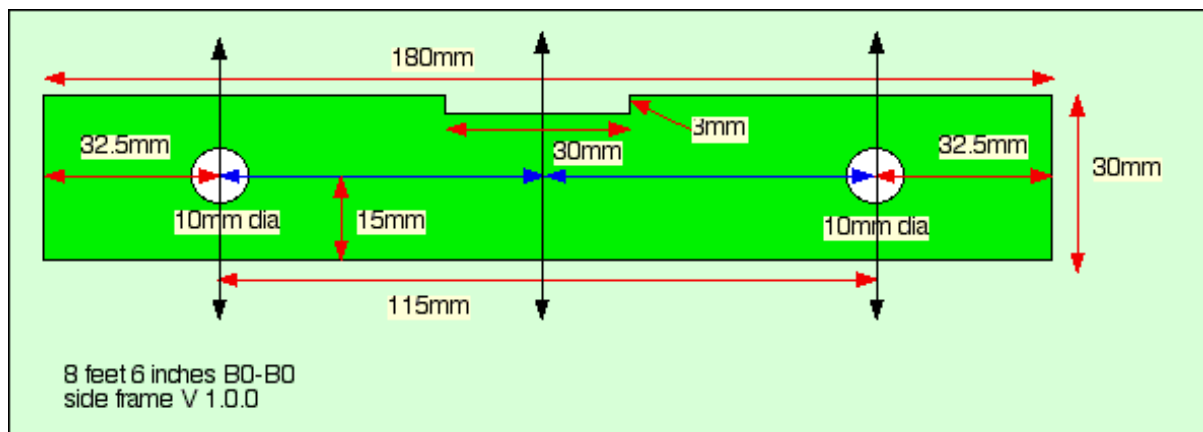

This is the motor face plate.

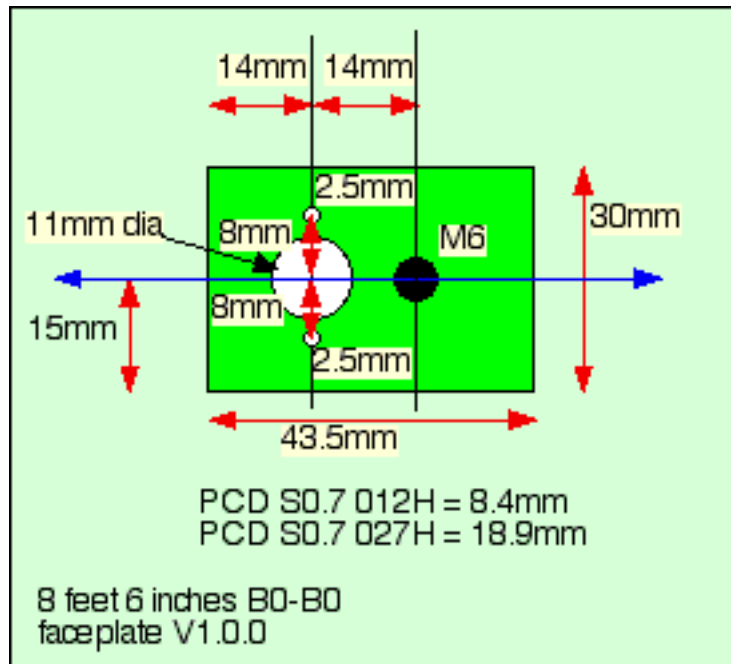

The brass boss of the RE360 motor is 10mm so we cut an 11mm hole for it to sit through. There are two 2.5mm holes to bolt the motor to the face plate. What is **not** shown are the REQUIRED 4mm holes arranged around the 11mm holes to allow air into the aero vent intakes of the motor. We opt to thread the stub axle that the 27 tooth gear sits on. This will give me a more secure fitting -either with "threadlock" or silver solder.

The next set of drawings will detail the transverse mounting plate, the vertical longitudinal strengthener, and the 6mm bore slip sheaves that lock the entire assembly in radial geometry with the axle.

This drawing completes the motor module. Which we will term as: **Module 03**.

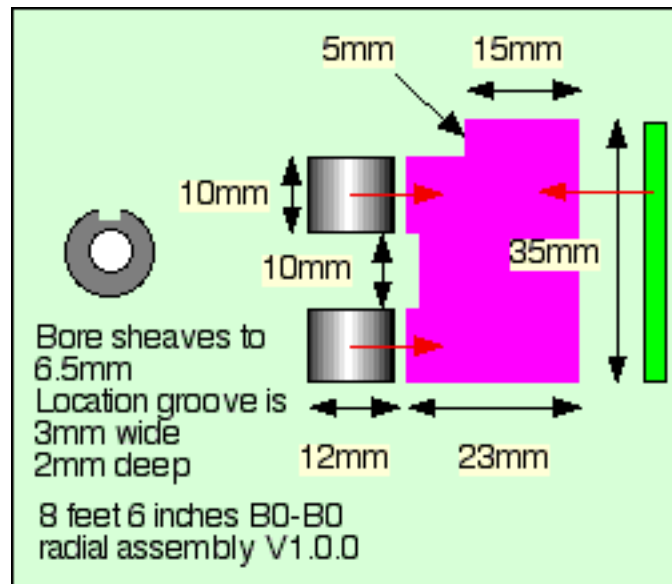

By simple extrusion or contraction of the side frames this will give the builder bogies from 6 feet 8 inches to 10 feet 6 inches. For bogies smaller than 6 feet 8 inches mount the Module 03 unit **Vertically**. However there **MUST** have some sort of side plate as the idler wheel will fall off its stub axle. The idler gear is held in position by the side frame.

The next bogie is the C0-C0 bogie of 6 feet 9 inches or 91mm axle spacing. We will opt for axles 1 and 3 horizontal and axle 2 vertical. **Axle 2 is the bugbear...** It will have to move sideways and up & down for compensation, plus it will have to take a 2m radius.

Mathematically the distance between them is **91.125mm** -however we have opted to use **90mm** as this makes the maths A LOT EASIER...

"This bogie is designed to run on 1mm gauge widened curves and has a minimum of 2mm side float".

That makes the minimum radius of the C0-C0 at 2.219m, (or 7 feet 3 1/2 inches). But there IS a very simple "dodge" that will enable us to get it around a 2m radius curve.

We make the axles **pivot...**

This has been done several times in locomotives, (notably the 1-E-1 locomotives of the old BLS), in effect we have turned a C0 bogie into an A-A-A bogie -or a powered "Clemenson" truck. This will produce a very smooth entry and exit to a curve at the expense of slightly rougher running on straights -which is a suitable trade off for the ease of design and the calculations involved.

Since the pivot points for the two ends of the bogie are equidistant from the axles the bogie will automatically adopt a radial facet to the curve. When entering a curve the leading bogie will force the trailing bogie to move radially inwards. To avoid undue friction a layer of grease should be applied between all sliding plates.

The 6 feet 9 inches C0-C0 bogie design above can be extruded to 8 feet 0 inches,

and provided all Module 3 units are mounted vertically -reduced to 6 feet 0 inches.

The pilot holes should be drilled in the BASEPLATE and PIVOTPLATE for the correct distances and then the builder simply drops a 6mm or 4mm drill through them. If the builder desires asymmetric axle spacing then the limit is 12 inches scale, further than this and the geometry of the plates begins to collapse.

The first reaction of a builder when seeing the above drawing is confusion. However if you break the layers down, everything is simple and logical.

The top layer shows the two horizontally mounted Module 03 units in U frames, with one Module 03 unit mounted vertically.

The middle layer shows the BASEPLATE which has the vertical support plates for the vertical Module 03. Drilled at 45mm are two 6mm holes which form the pivots.

The bottom layer shows the PIVOTPLATE these hold the U frames for the two horizontally mounted Module 03 units. These have extended arms which have 4mm holes in them. The 4mm holes are on the axle line of the centre axle.

The last layer shows the LINKPLATE which connects the two arms of the PIVOTPLATE. The LINKPLATE mounts above the BASEPLATE with the PIVOTPLATES below it

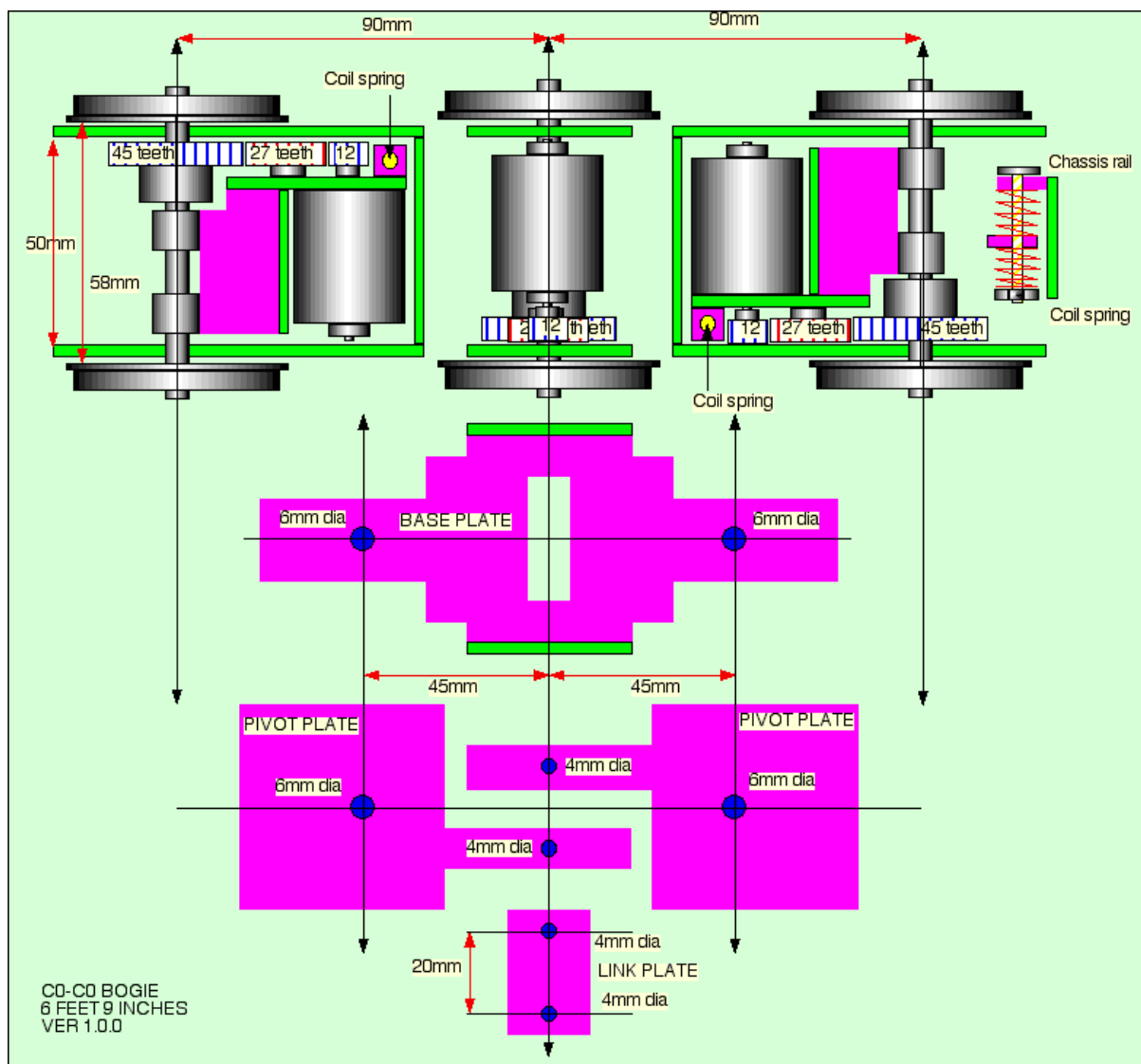

The next thing to design is the additions to the C0-C0 bogie to turn it into a 1C0-C01 or even a 1C01-1C01 -if required.

There are three design problems to this... Since the bogie is no longer symmetrical, the behaviour of it varies as to its direction of travel. The pivot point of the bogie while still above axle 2 is subject to shimmying more than it would be expected on straights. Now that there are 4 axes hitting a corner the unpowered front axle will hit the super elevation first and the "shock" cause the first power axle to de-rail.

The method we intend using is to isolate the front axle from the bogie and use springs to absorb the impact and to transfer the sideways force to the bogie in a more "gentle" manner.

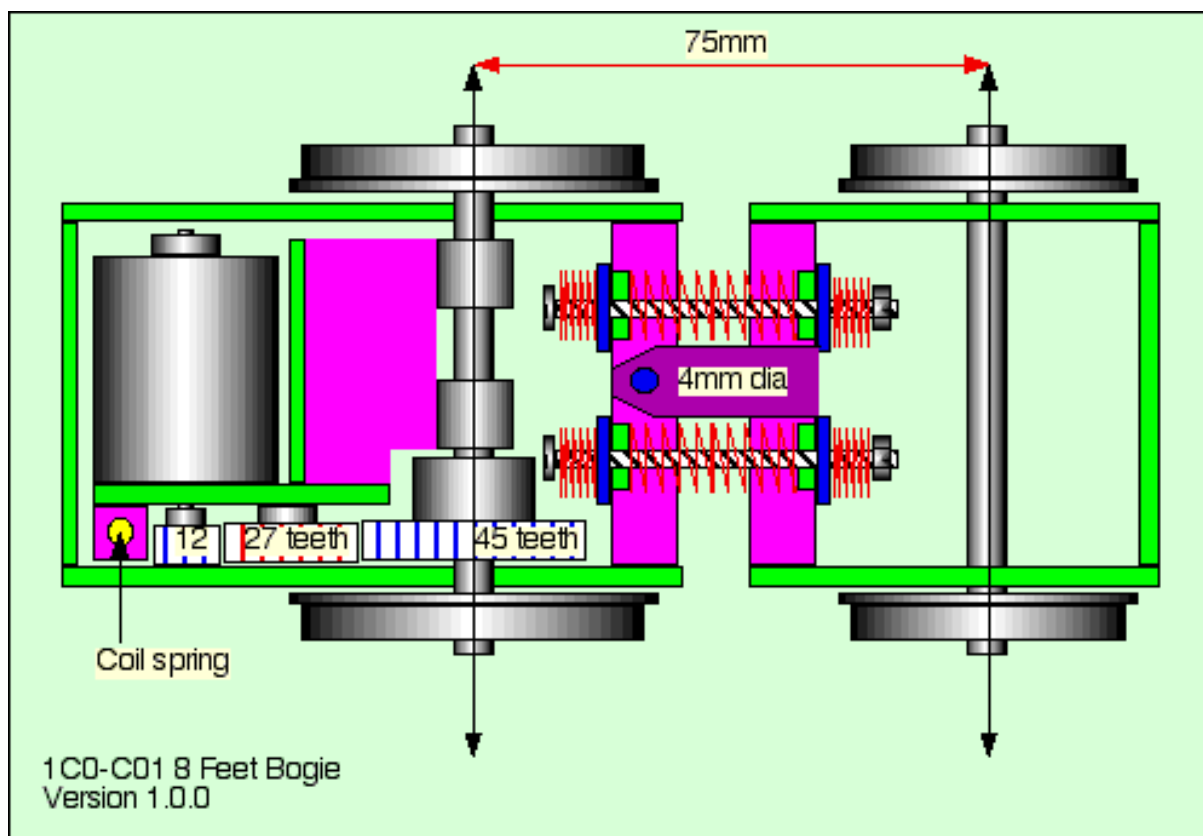

The front is held in place by tensions on two sets of springs, the nuts and bolts are held in tension by a spring either side of the transverse plate. Thus there are three springs in a line. There is a damping rubber grommet either side of the inner springs. This helps destroy shimmy. The front can thus turn and twist and steer as required. For increased stability at speed the 1C0-C01 bogie should have more weight located over the leading and trailing axles. This could be anything from a chunk of scrap embedded in epoxy -to a cast lump of lead.

Suspension for the Bogies

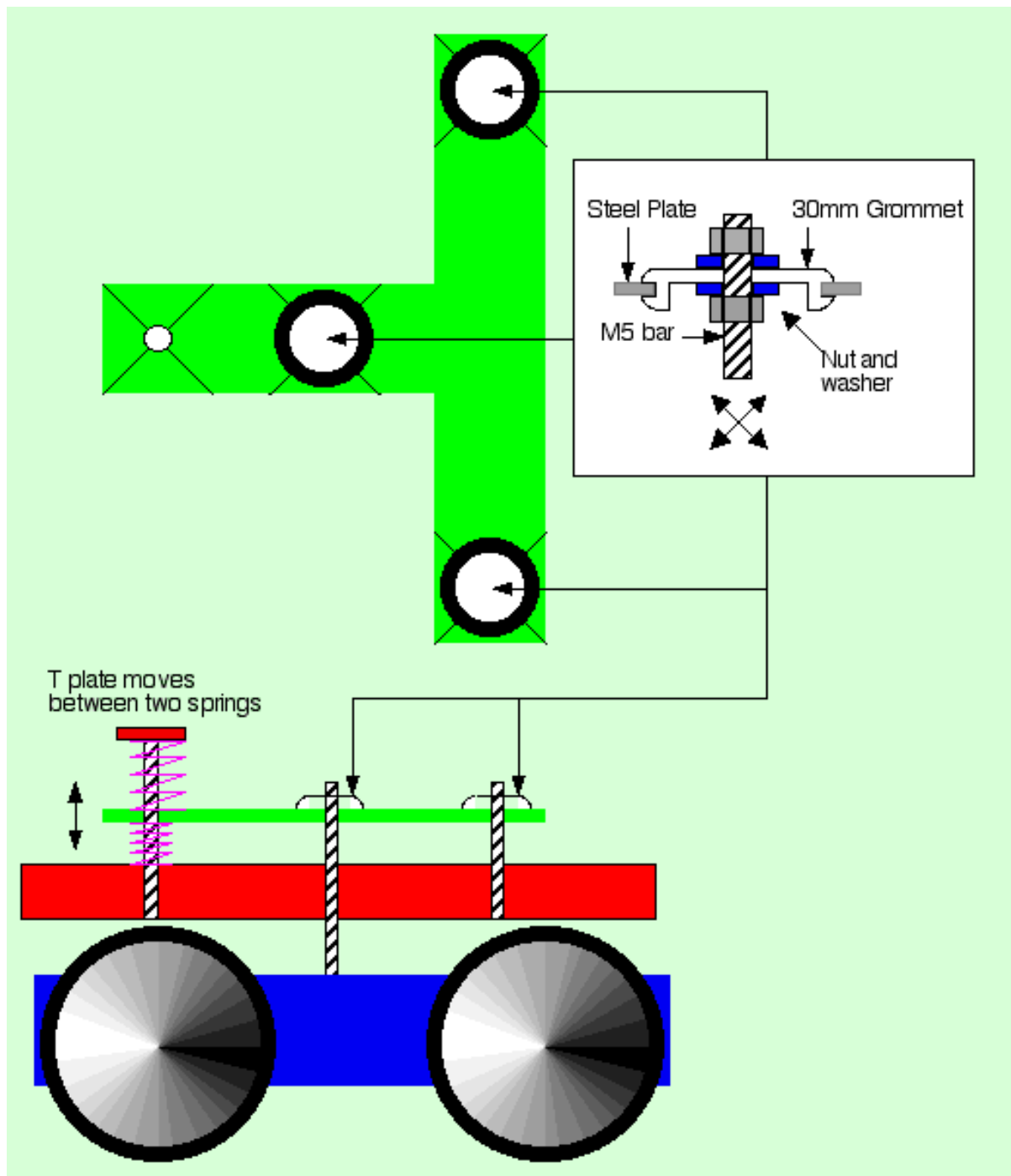

The T bar is suspended above the frame and the 30mm rubber grommet blanking pieces, (from Maplins), are held in place by nuts and washers. This enables the 5mm threaded bar to move in a damped motion. The two arms of the T bar are directly above the chassis rails and the third is directly above a Cross member. The third is held between two sets of springs and provides the vertical motion of the bogie as the axles are not sprung.

The sprung bases of the T pieces should face the ends of the loco.

Because the rotational forces are taken through one pivot point it is possible (if desired) to attach a bar from this to the end of the loco -with the coupling on it. This is normally referred to as a "Troll Bar" and is normal on Scandinavian locos. Mount the hooks on either the Troll Bar, the end of the Bogie or the Buffer beam.

The ladder chassis frame is simply made from U sections of Aluminium or Steel from B&Q... They are held in place by L brackets from the same part of the store. 4mm "pop" rivets are used to hold them in place and then the builder would normally weld up the seams to produce a rigid structure.

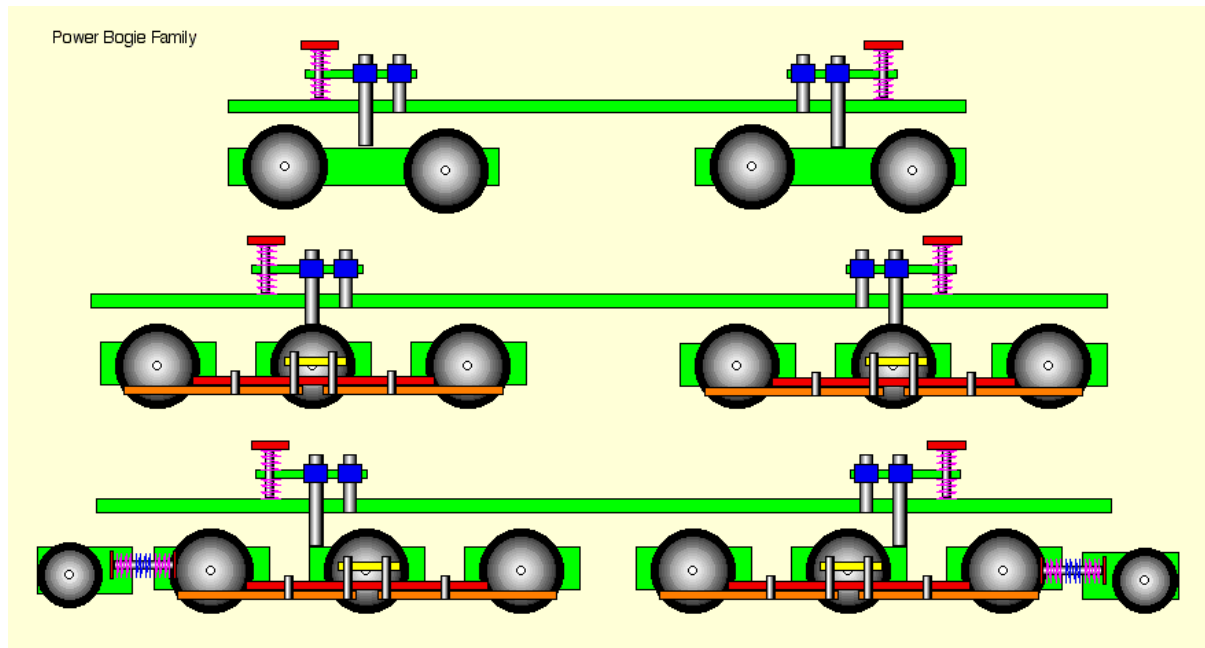

Note: the pivot point from the 1C0-C01 bogie is offset to provide a symmetric loading to forces. Thus the pivot for the bogie is at the centre of the **Mass** and not of the **Length** for rotation. This distance is 145mm from the rear axle.

If the builder is producing a C0-C0 bogie with asymmetric axle spacing then the same care should be taken to rotate the bogie around the centre of Mass.

Variations on a Theme.

It would be possible to produce a Module 04 from a second 3mm groove cut into the axle sheave at right angles to the initial one. This would produce a 90 degree Vee engine rated at 8W. The square space between the 23mm x 35mm plate would have to be re-enforced by a suitable off cut of pine -or some ply triangles epoxied into it. The sprung mass of the new unit would be twice that of a single -so some form of damping would be required both horizontally and vertically.

Commercial sources of wheels.

Brandbright	RSA34P	42mm	= 3 feet 1 inches
Brandbright	RSA37	47mm	= 3 feet 5.76 inches
Alan Headech	5110	50mm	= 3 feet 8.5 inches -10 spokes
Kennion Bros	K5	50.80mm	= 3 feet 9.12 inches

If there is no "exact fit" maybe it might be possible for the builder to produce specific wheels. 50mm and 55mm dia steel bar are common sizes and seem to retail at about £1.54p and £1.94p per **inch(?)** respectively, this would make 2 wheels per inch -as a guide.

The following wheels could be cut from the following dia bar:

3 feet 0 inches	1 5/8ths inch dia bar @ £1.05p per inch
3 feet 3 inches	50mm dia bar @ £1.54p per inch
3 feet 8 inches	55mm dia bar @ £1.94p per inch